

cliff

Design: Sture Eng & Dan Ihreborn







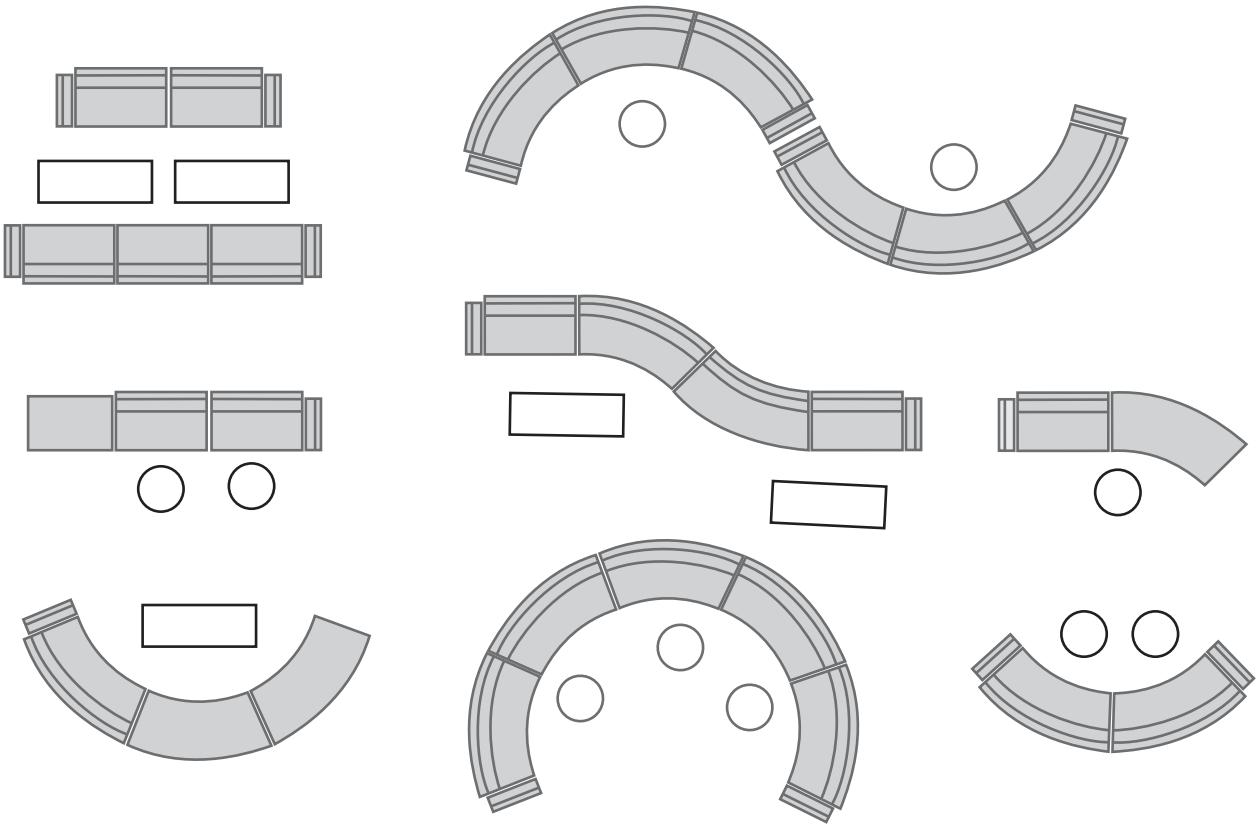
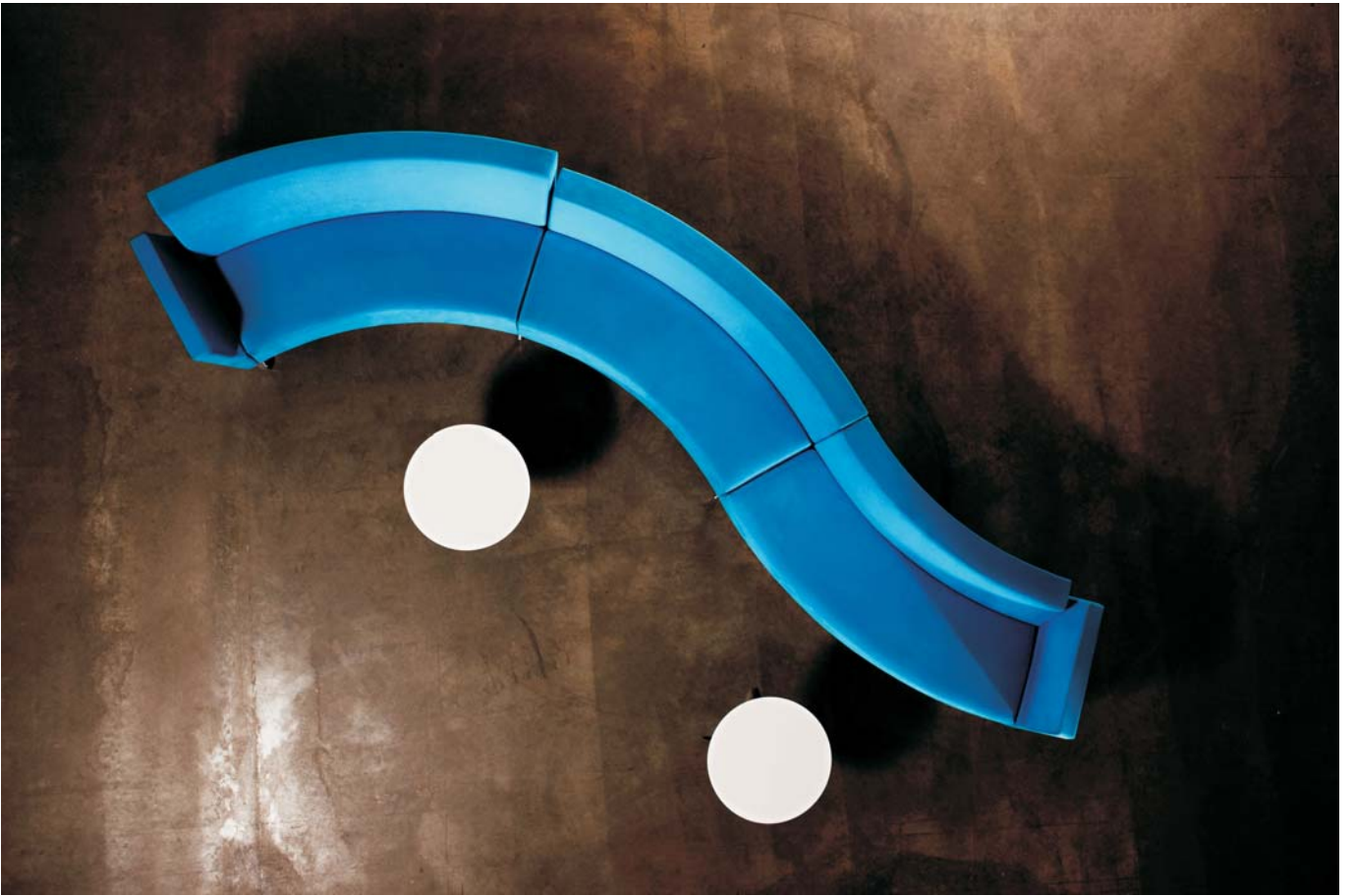

Radius (outer): 2600